

SERPAC 1224 H45 BOOT

Electronic Enclosures

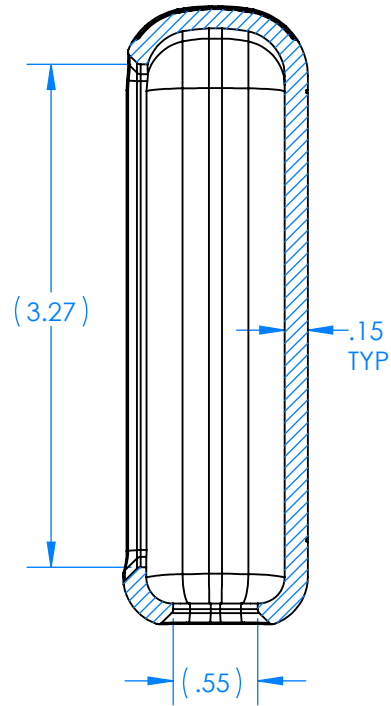

SECTION A-A

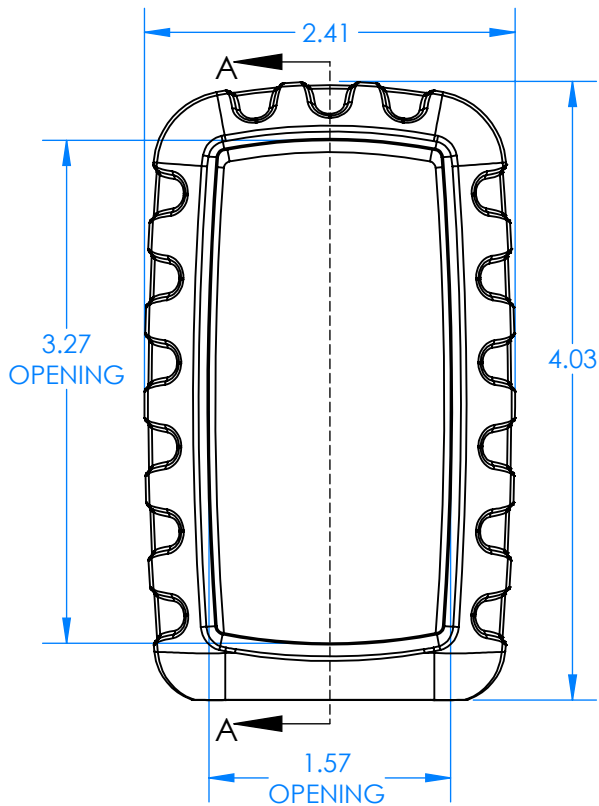
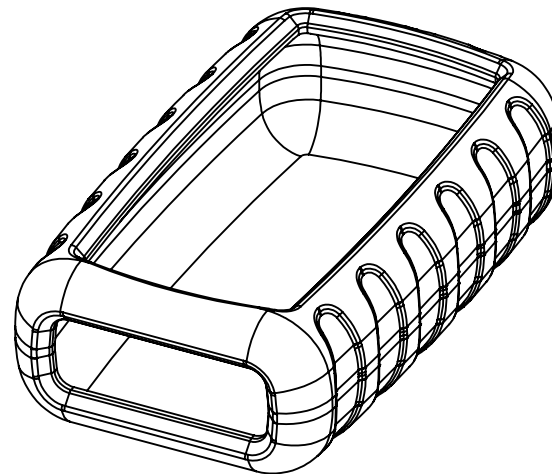
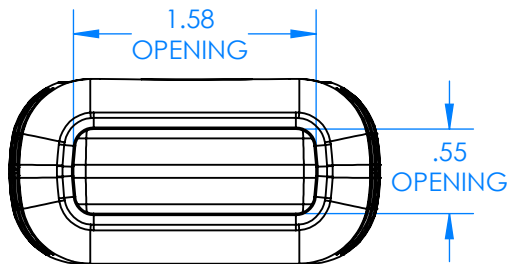
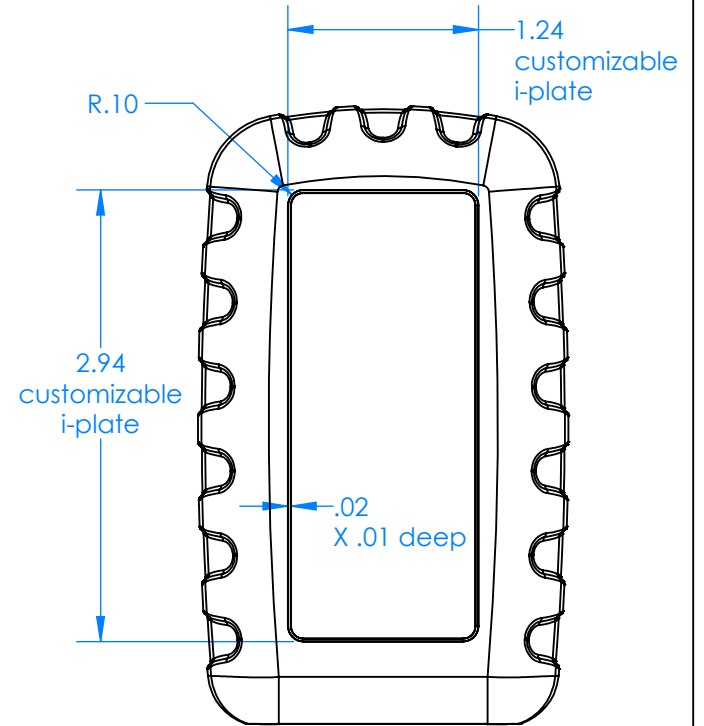
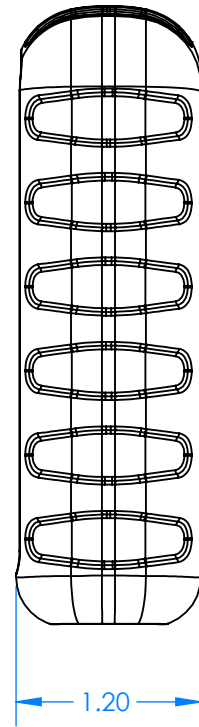

Notes:

- 1) All components are RoHS Compliant.
- 2) Enclosure weight .11 lb / 52 g