

SERPAC 273

ELECTRONIC ENCLOSURES

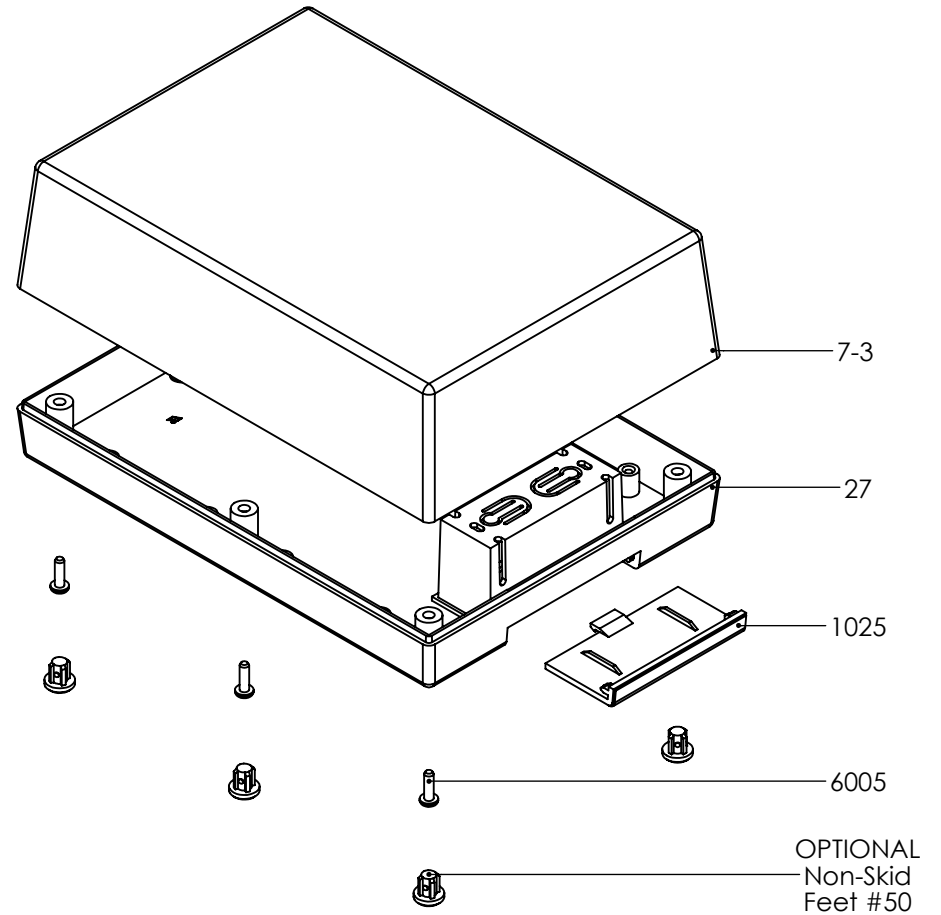
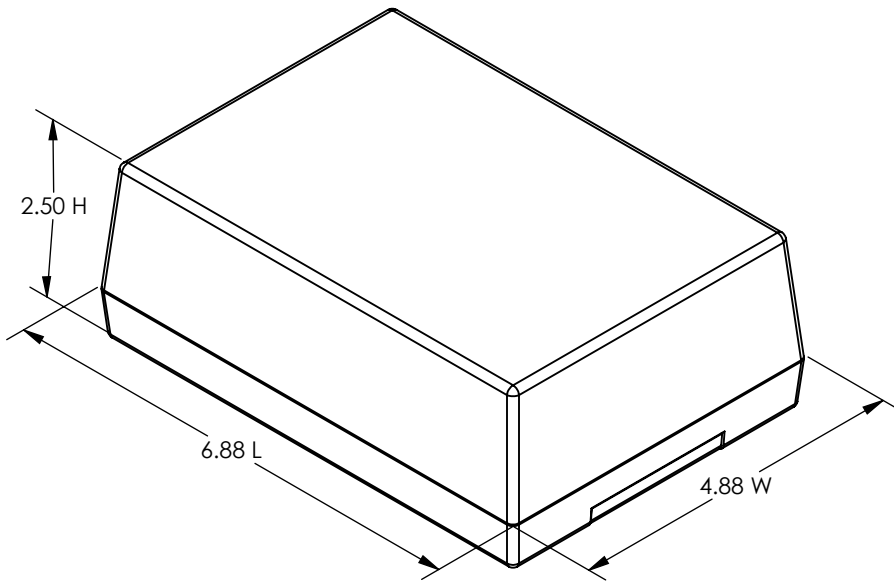

PART NO.	DESCRIPTION (Included)	ACCESSORIES (Optional)	
7-3	Top	PART NO.	DESCRIPTION
27	9V Bottom	1040	2AA Battery Holder
6005	#4X3/8" Self-Tapping Screw (6)	50	Non-skid Feet
1025	Battery Cover	60	Standoff Hole
		61	Standoff Post

Notes: Enclosure weight .49 lb / 221 g
 1) Enclosure meets or exceeds IP40 and NEMA 1
 2) Circuit Board drawings see sheet 3.
 3) All components are RoHS Compliant.
 4) Material: Top and Bottom ABS.

SERPAC 273

ELECTRONIC ENCLOSURES

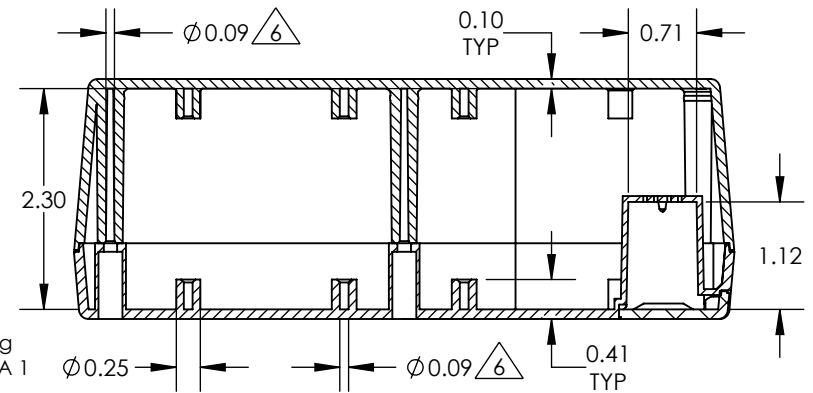
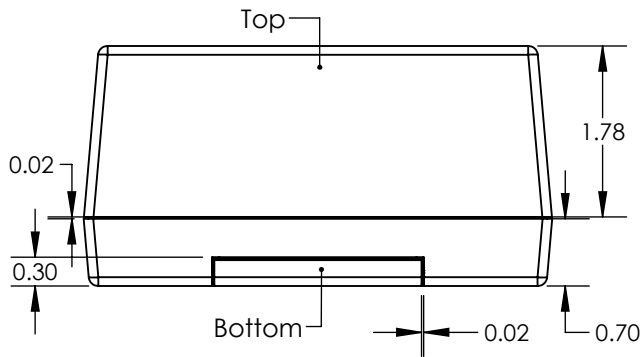
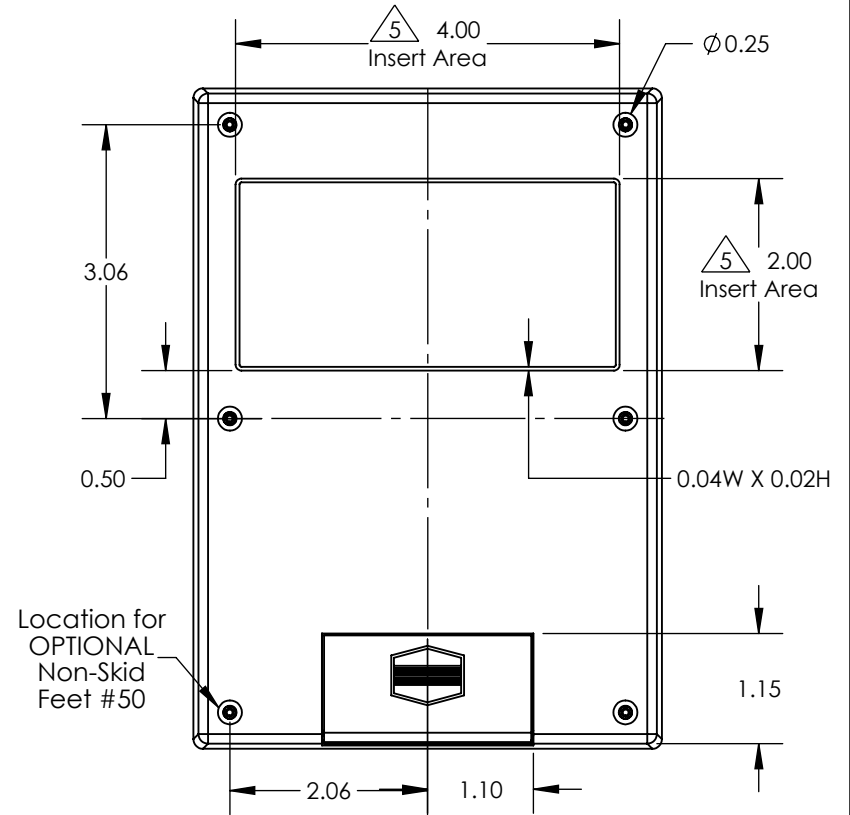
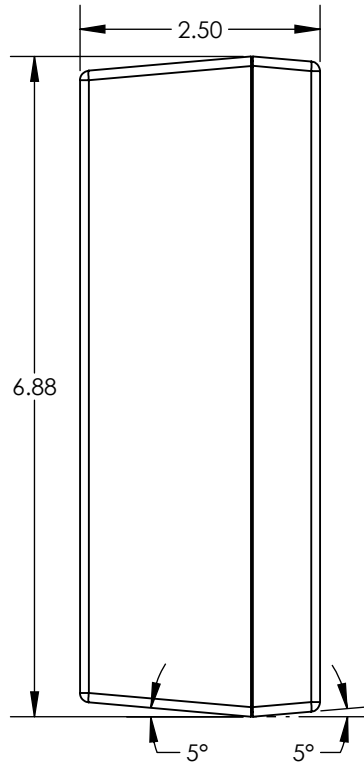
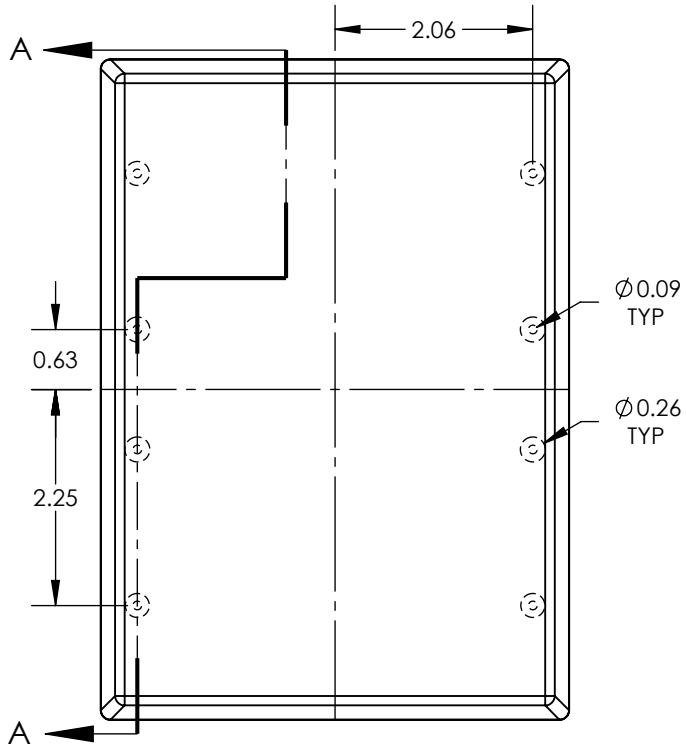

- Notes:
- 1) Enclosure weight .49 lb / 221 g
 - 2) Enclosure meets or exceeds IP40 and NEMA 1
 - 3) Circuit Board drawings see sheet 3.
 - 4) All components are RoHS Compliant.
 - 5) Material: Top and Bottom ABS.
 - 6) Material: PCB Bosses accept #4 self tapping screw.

SECTION A-A

SERPAC 273 CIRCUIT BOARD

ELECTRONIC ENCLOSURES

Top Option

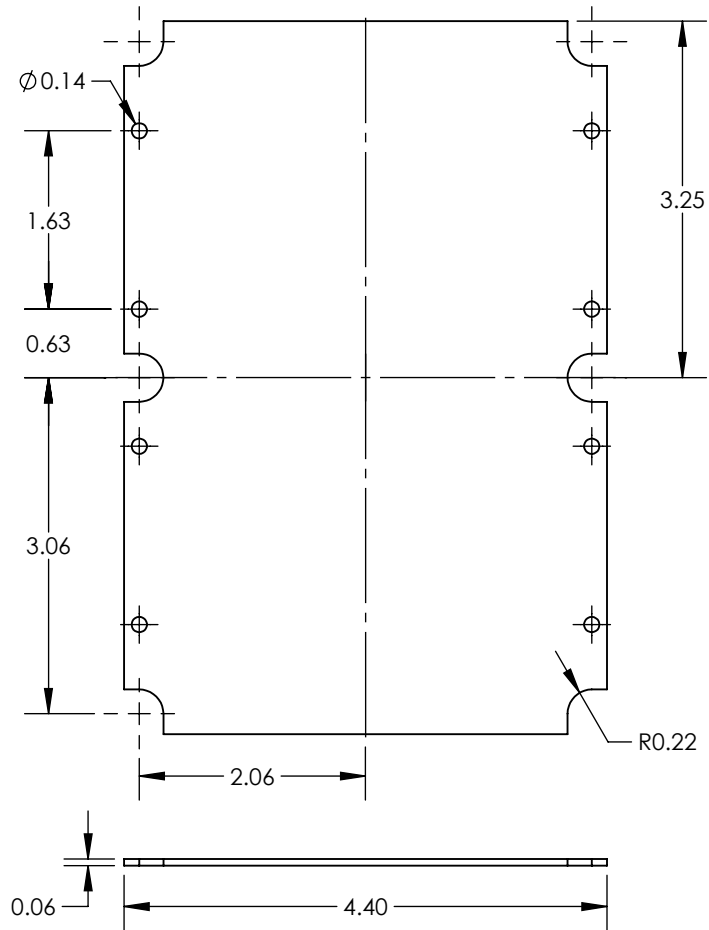

Bottom Option

