

SERPAC 253

ELECTRONIC ENCLOSURES

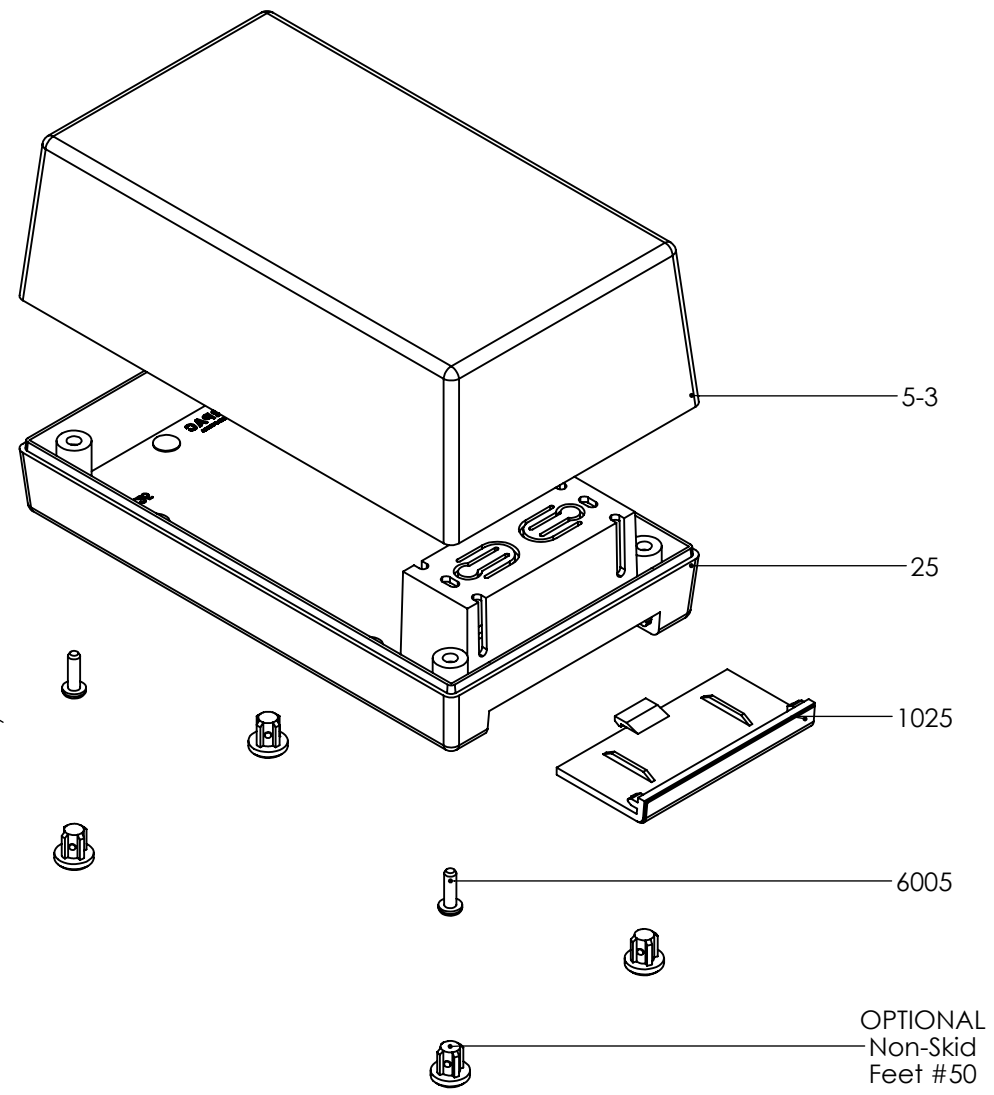
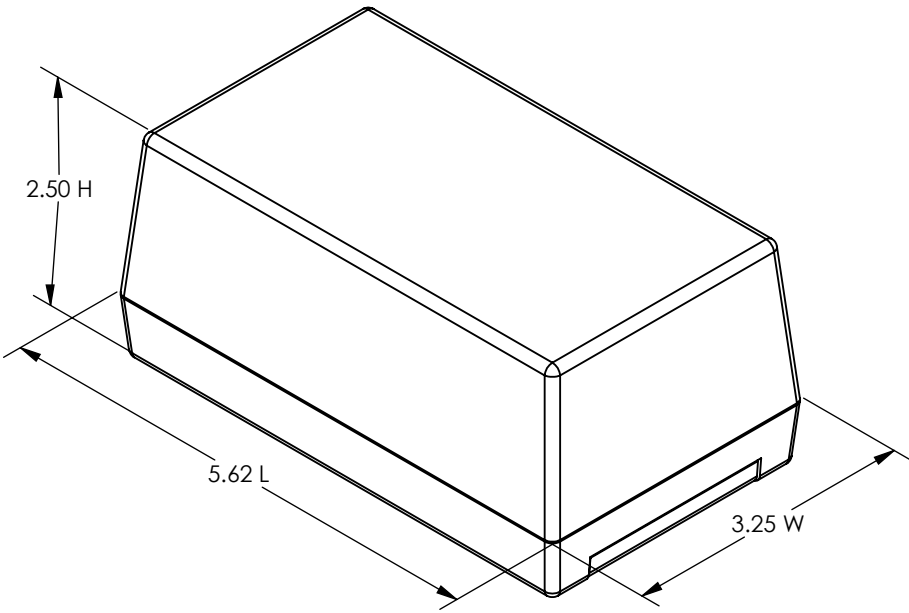

PART NO.	DESCRIPTION (Included)	ACCESSORIES (Optional)	
5-3	Top	PART NO.	DESCRIPTION
25	9V Bottom	1030	Pocket Clip
6005	#4X3/8" Self-Tapping Screw (4)	1040	2AA Battery Holder
1025	Battery Cover	50	Non-skid Feet
		55	Key Holder
		60	Standoff Hole
		61	Standoff Post

Notes: Enclosure weight .32 lb / 146 g
 1) Enclosure meets or exceeds IP40 and NEMA 1
 2) Circuit Board drawings see sheet 3.
 3) All components are RoHS Compliant.
 4) Material: Top and Bottom ABS.
 5) Customizable molding areas.

SERPAC 253

ELECTRONIC ENCLOSURES

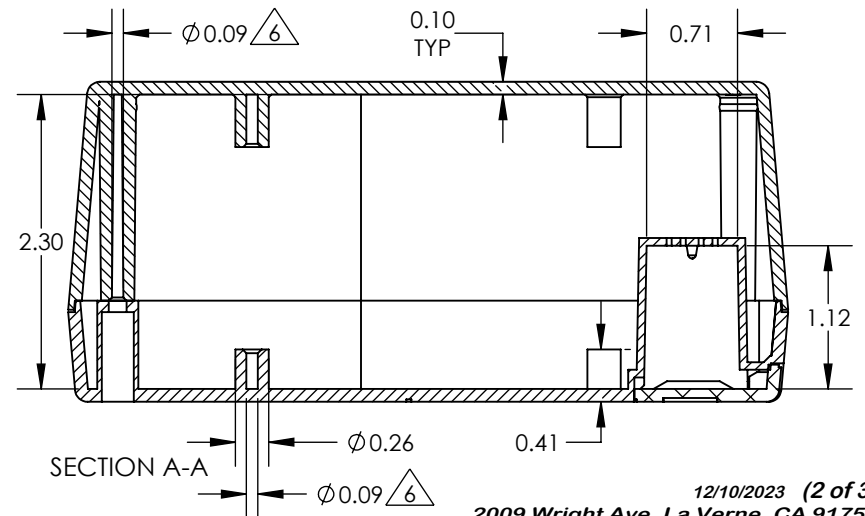
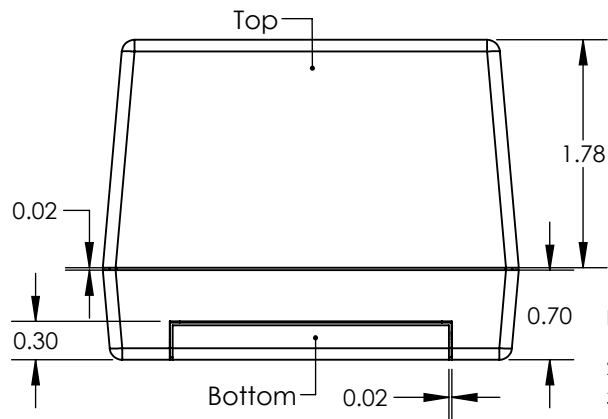
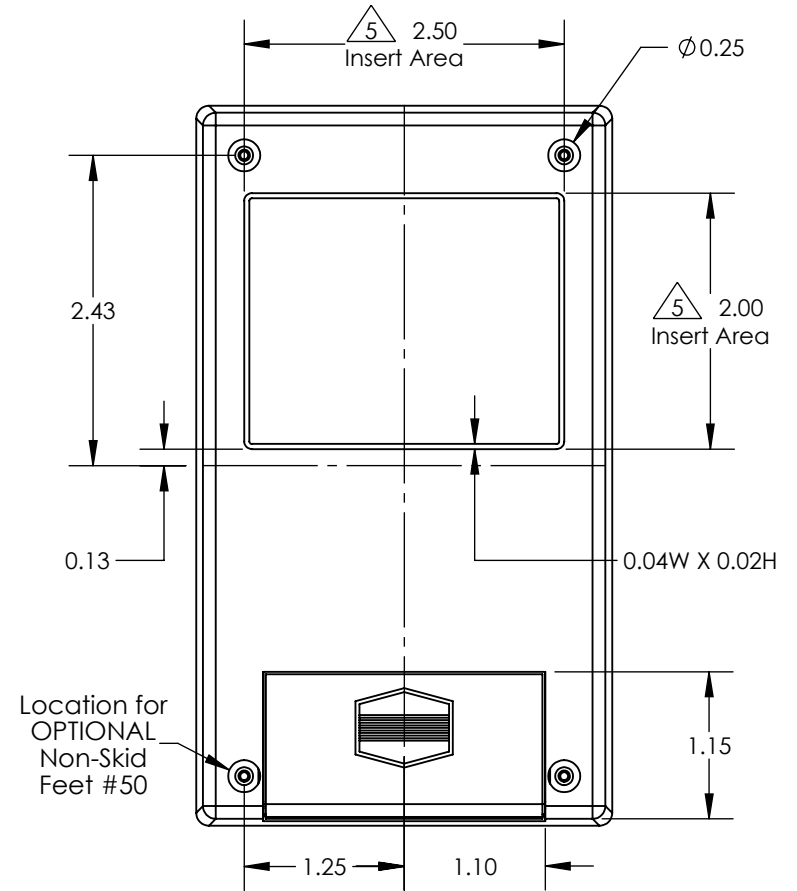
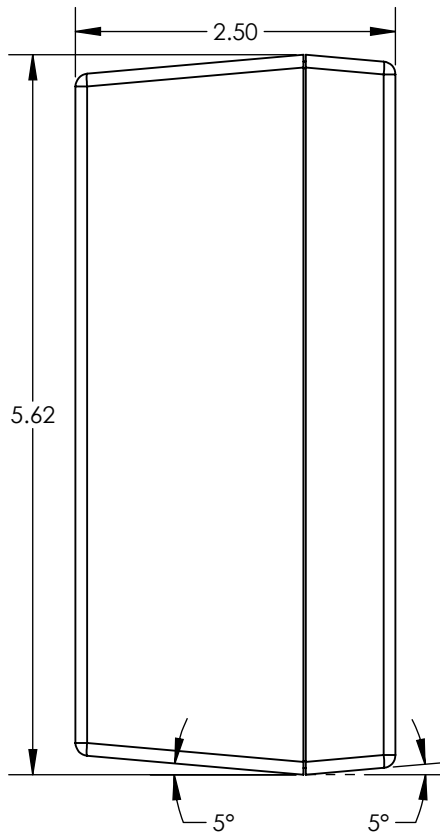
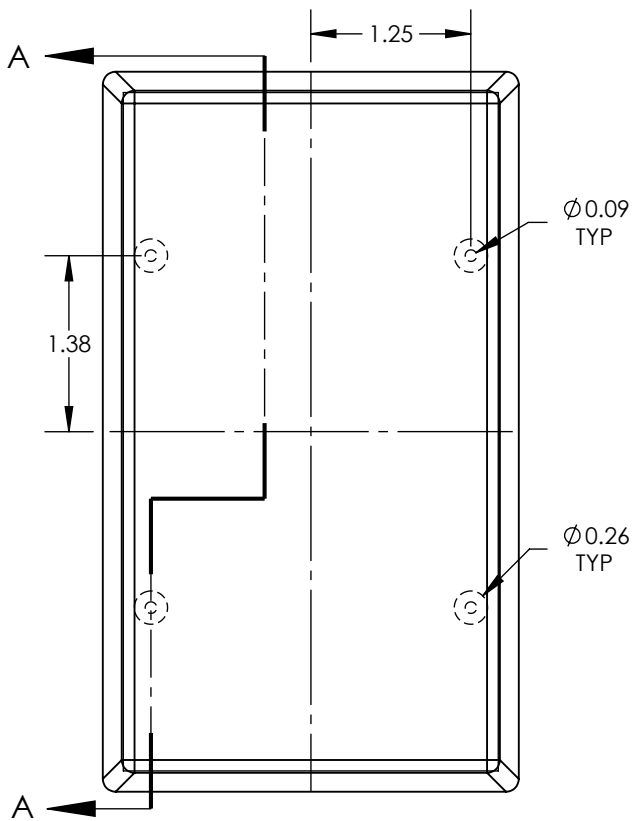

- Notes:
- Enclosure weight .32 lb / 146 g
 - 1) Enclosure meets or exceeds IP40 and NEMA 1
 - 2) Circuit Board drawings see sheet 3.
 - 3) All components are RoHS Compliant.
 - 4) Material: Top and Bottom ABS.
 - 5) Customizable molding areas. $\triangle 5$
 - 6) PCB Bosses accept #4 self tapping screw. $\triangle 6$

SERPAC 253 CIRCUIT BOARD

ELECTRONIC ENCLOSURES

Top Option

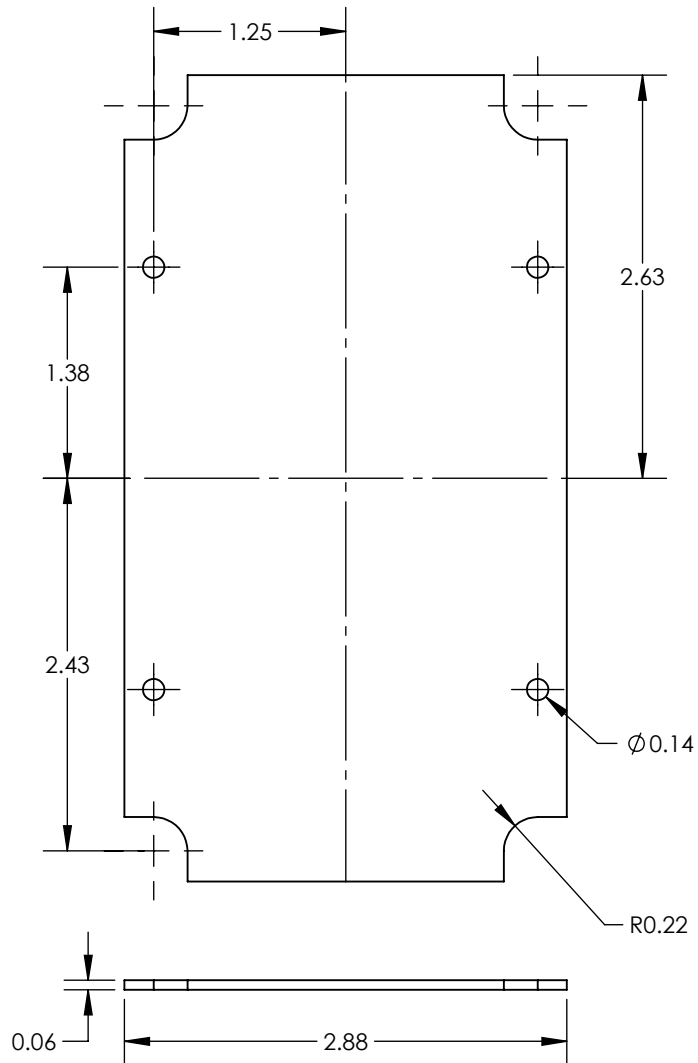

Bottom Option

