

SERPAC 221

ELECTRONIC ENCLOSURES

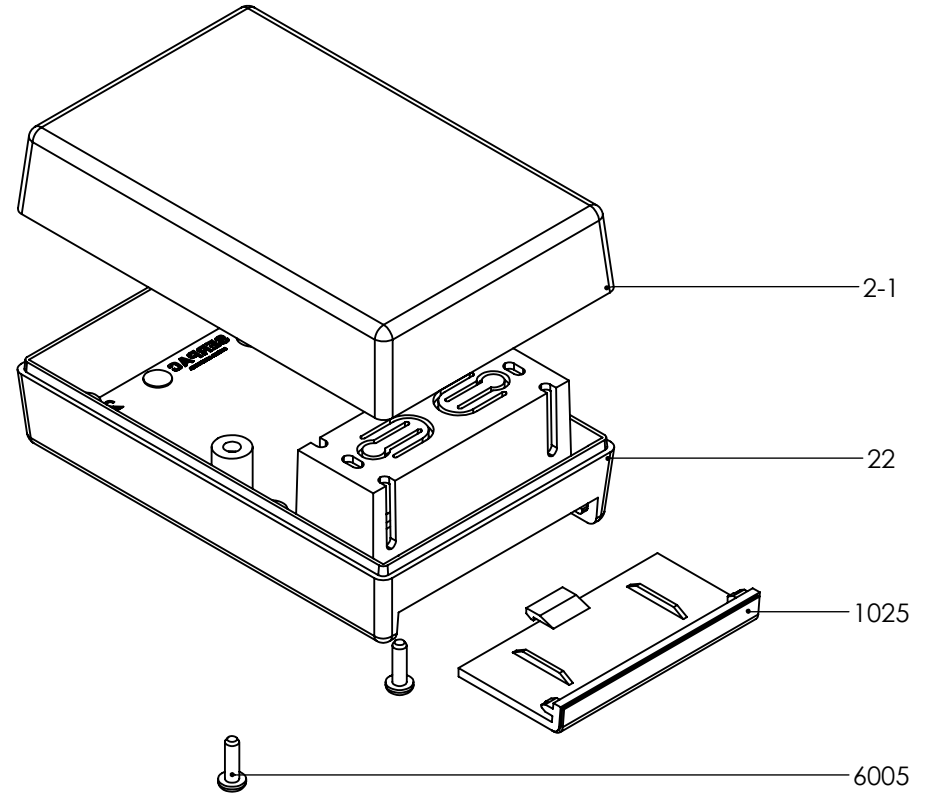
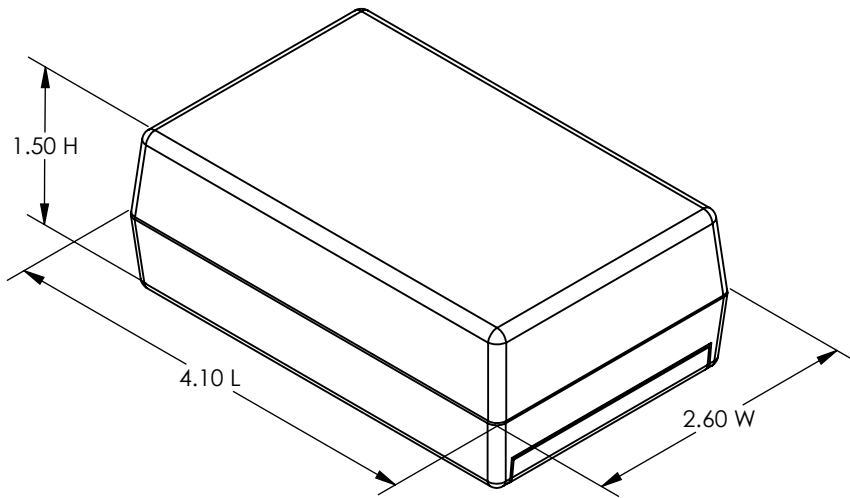

PART NO.	DESCRIPTION (Included)	ACCESSORIES (Optional)	
		PART NO.	DESCRIPTION
2-1	Top	1030	Pocket Clip
22	9V Bottom	55	Key Holder
6005	#4X3/8" Self-Tapping Screw (2)	60	Standoff Hole
1025	Battery Cover	61	Standoff Post

Notes: Enclosure weight .17 lb / 78 g
 1) Enclosure meets or exceeds IP40 and NEMA 1
 2) Circuit Board drawings see sheet 3.
 3) All components are RoHS Compliant.
 4) Material: Top and Bottom ABS.

SERPAC 221

ELECTRONIC ENCLOSURES

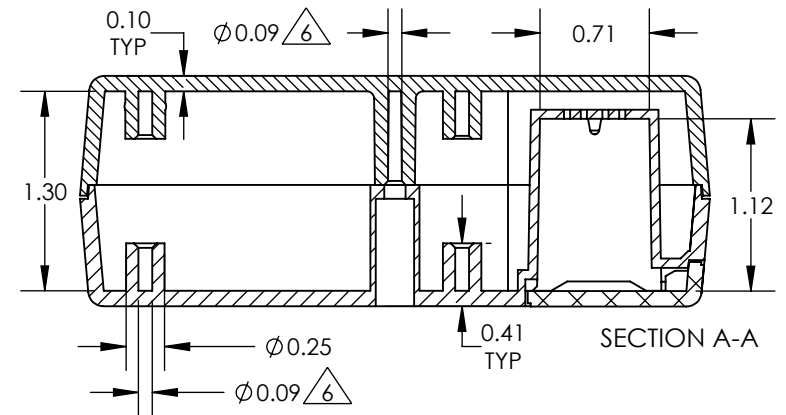
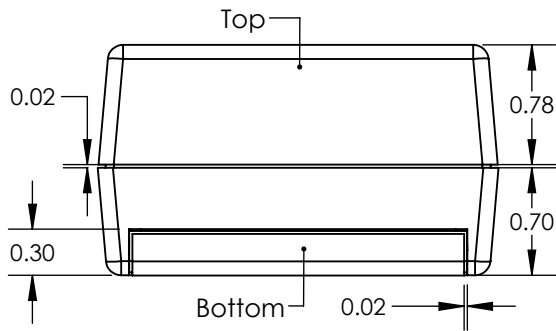
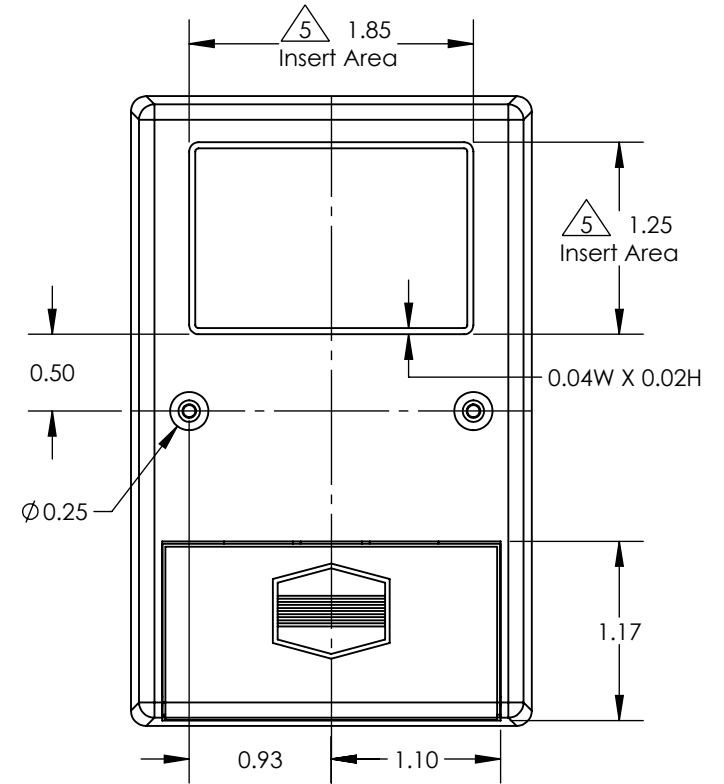
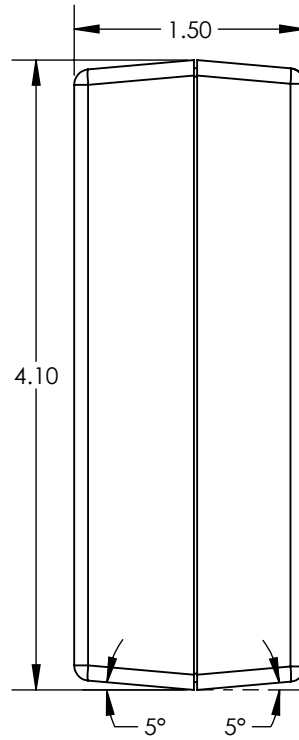
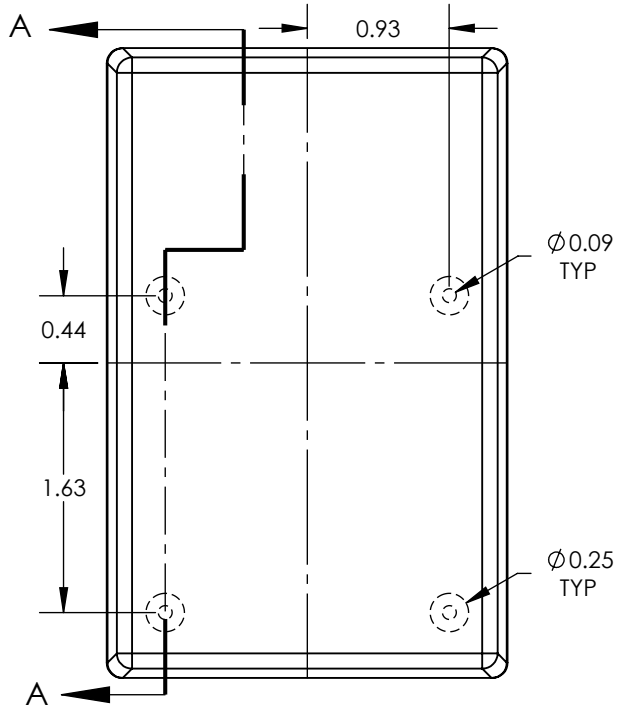

- Notes:
- Enclosure weight .17 lb / 78 g
 - 1) Enclosure meets or exceeds IP40 and NEMA 1
 - 2) Circuit Board drawings see sheet 3.
 - 3) All components are RoHS Compliant.
 - 4) Material: Top and Bottom ABS.
 - 5) Customizable molding areas. $\triangle 5$
 - 6) PCB Bosses accept #4 self tapping screw. $\triangle 6$

SERPAC 221 CIRCUIT BOARD

ELECTRONIC ENCLOSURES

Bottom Option

