

SERPAC 094

ELECTRONIC ENCLOSURES

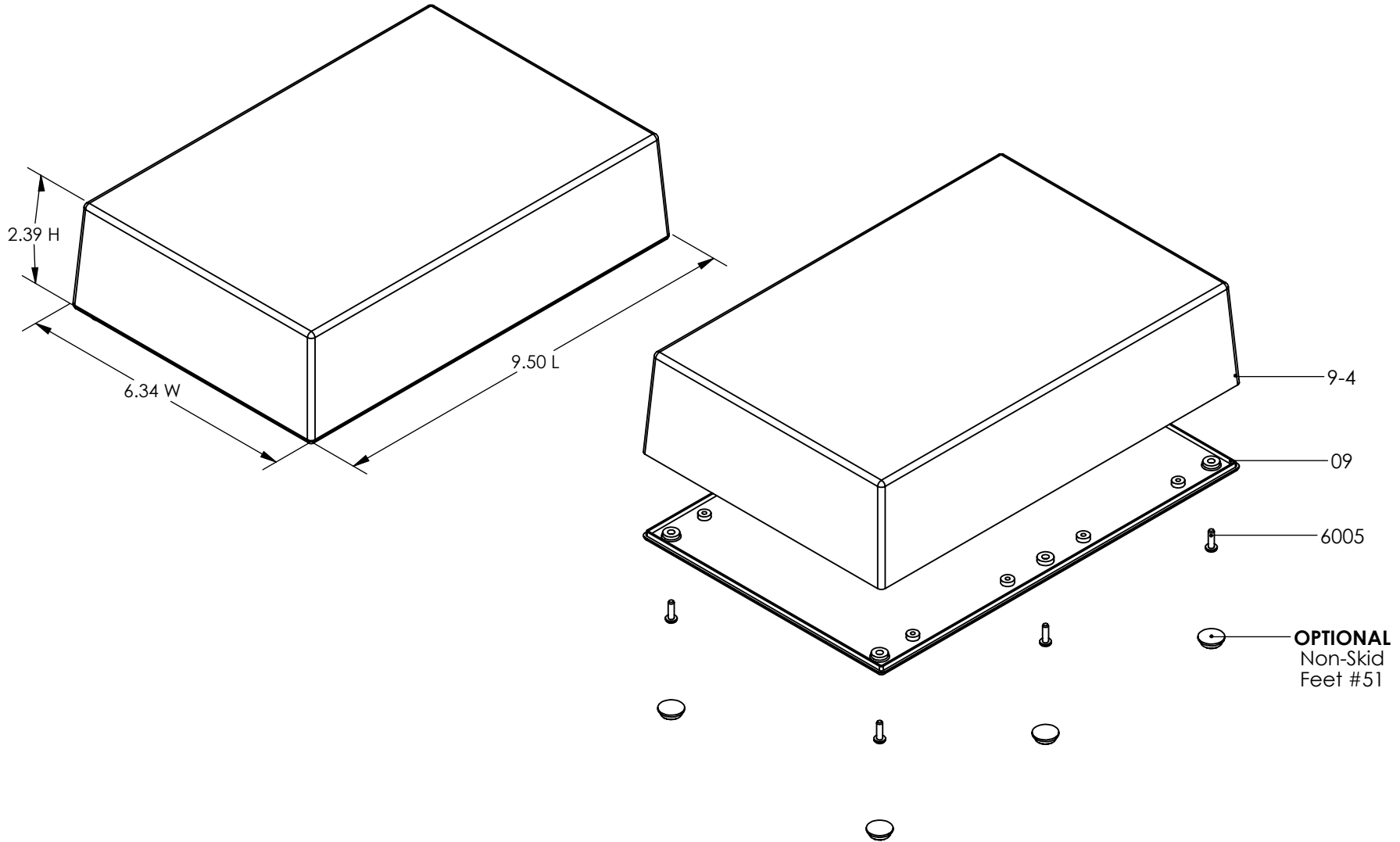

PART NO.	DESCRIPTION (Included)	ACCESSORIES (Optional)	
9-4	Top	PART NO.	DESCRIPTION
09	Bottom	51	Non-skid Feet
6005	#4X3/8" Self-Tapping Screw (6)	1040	2AA Battery Holder
		60	Standoff Hole
		61	Standoff Post

- Notes: Enclosure weight .69 lb / 312 g
- 1) Enclosure meets or exceeds IP40 and NEMA 1
 - 2) Circuit Board drawings see sheet 3.
 - 3) All components are RoHS Compliant.
 - 4) Material: Top and Bottom ABS.

SERPAC 094

ELECTRONIC ENCLOSURES

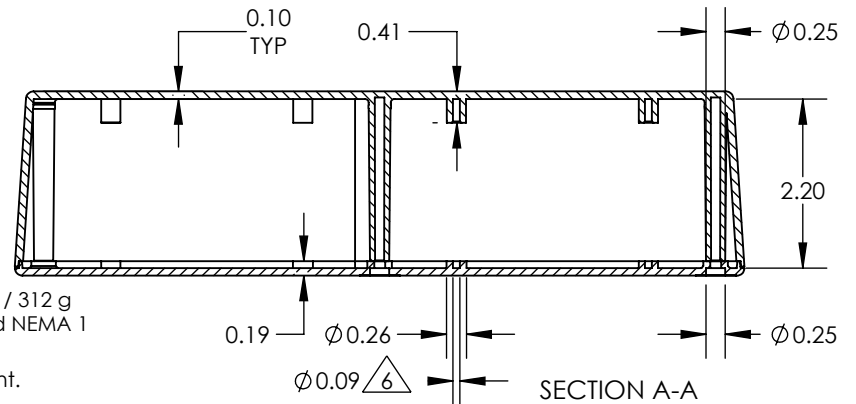
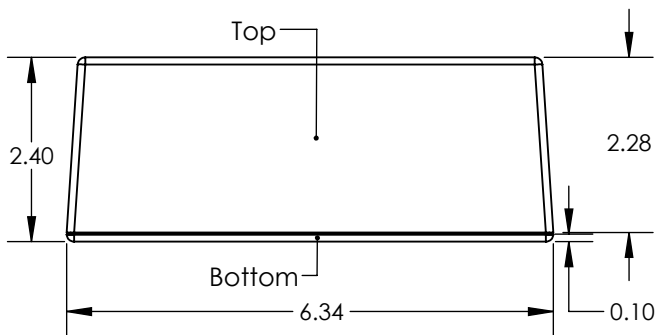
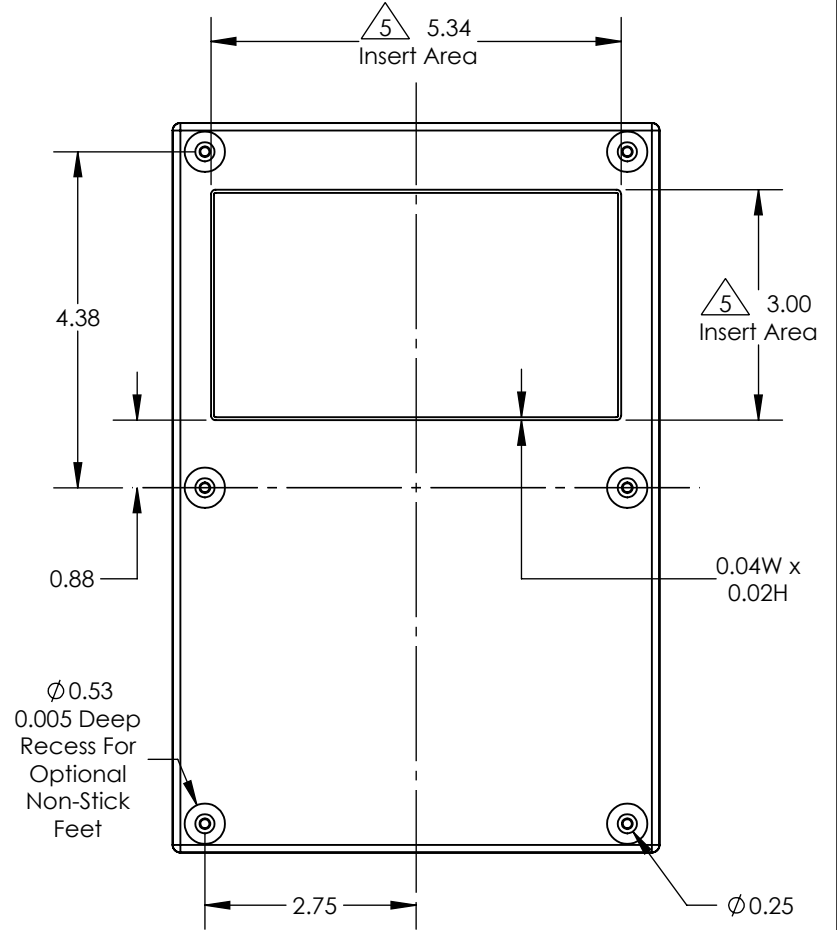
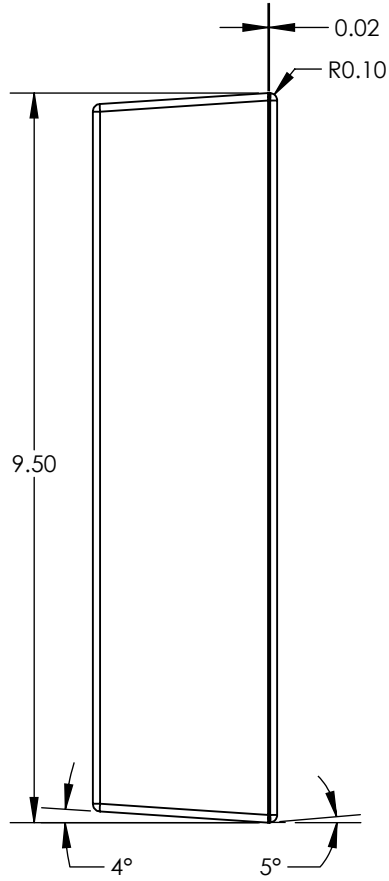
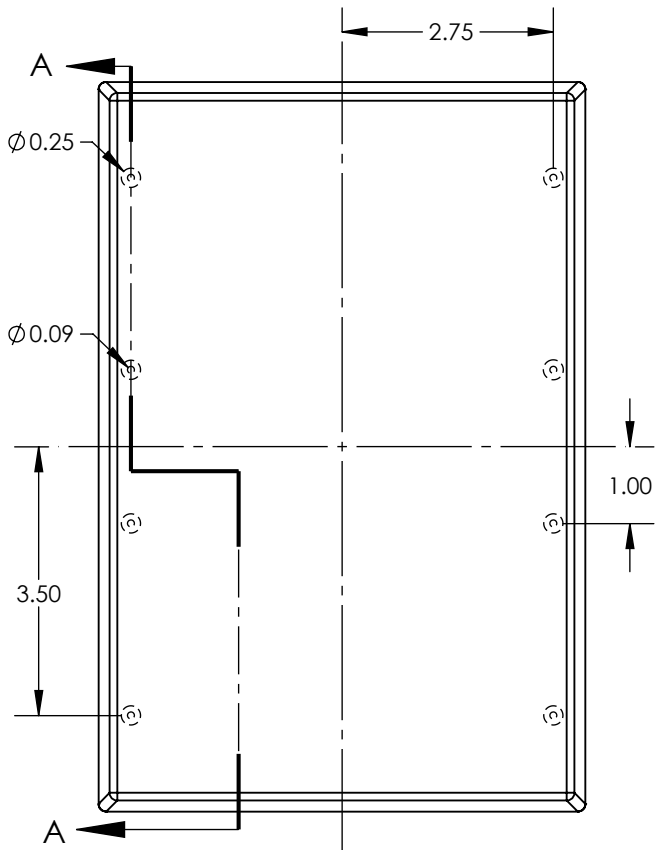

- Notes:
- 1) Enclosure weight .69 lb / 312 g
 - 2) Enclosure meets or exceeds IP40 and NEMA 1
 - 3) Circuit Board drawings see sheet 3.
 - 4) All components are RoHS Compliant.
 - 5) Material: Top and Bottom ABS.
 - 6) Customizable molding areas. $\triangle 5$
 - 7) PCB Bosses accept #4 self tapping screw. $\triangle 6$

SERPAC 094 CIRCUIT BOARD

ELECTRONIC ENCLOSURES

Top & Bottom Option

