

SERPAC 052

ELECTRONIC ENCLOSURES

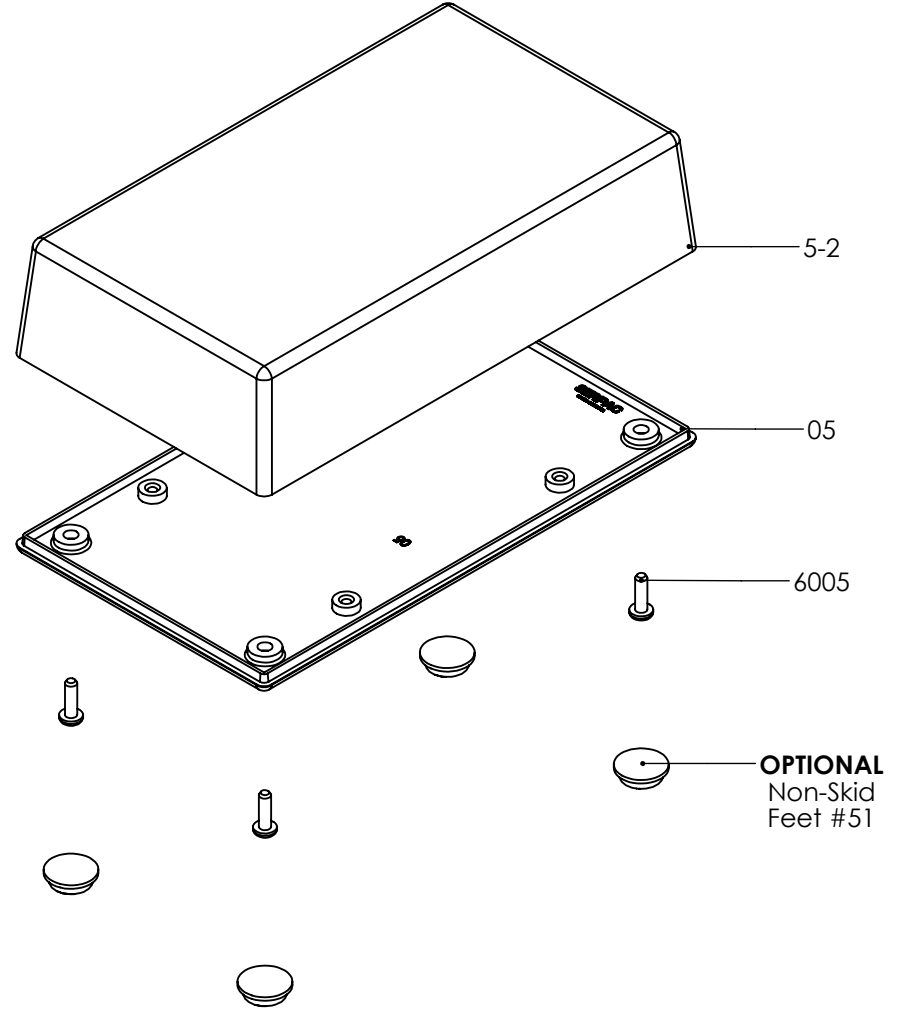
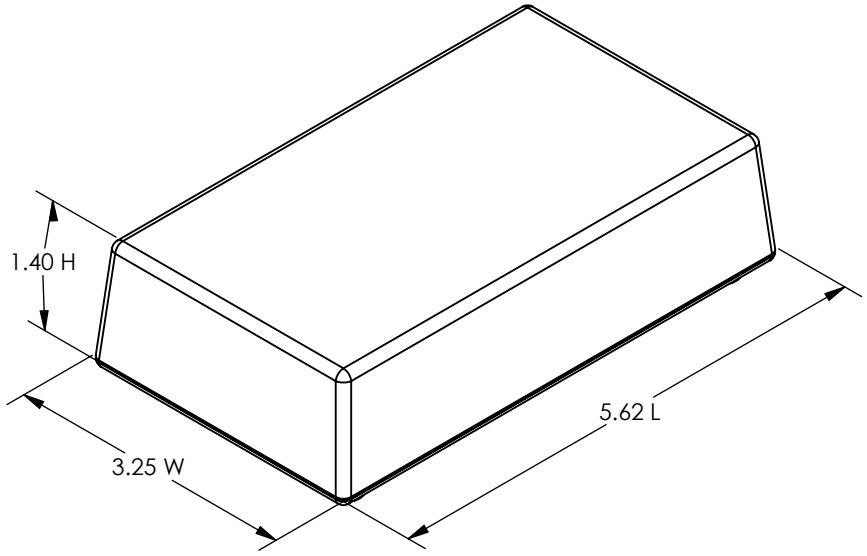

PART NO.	DESCRIPTION (Included)	ACCESSORIES (Optional)	
5-2	Top	PART NO.	DESCRIPTION
05	Bottom	51	Non-skid Feet
6005	#4X3/8" Self-Tapping Screw (4)	1030	Pocket Clip
		1040	2AA Battery Holder
		55	Key Holder
		60	Standoff Hole
		61	Standoff Post

Notes: Enclosure weight .22 lb / 101 g
 1) Enclosure meets or exceeds IP40 and NEMA 1
 2) Circuit Board drawings see sheet 3.
 3) All components are RoHS Compliant.
 4) Material: Top and Bottom ABS.

SERPAC 052

ELECTRONIC ENCLOSURES

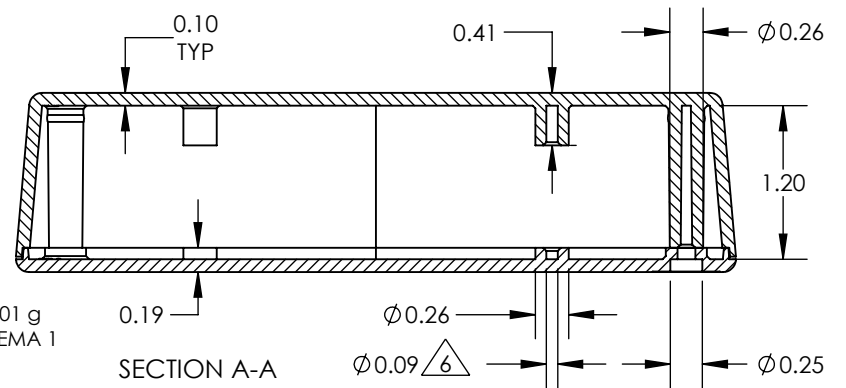
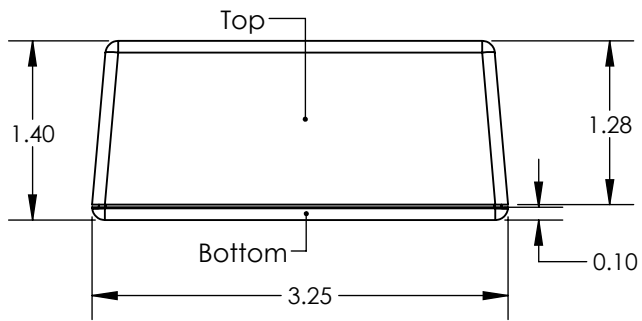
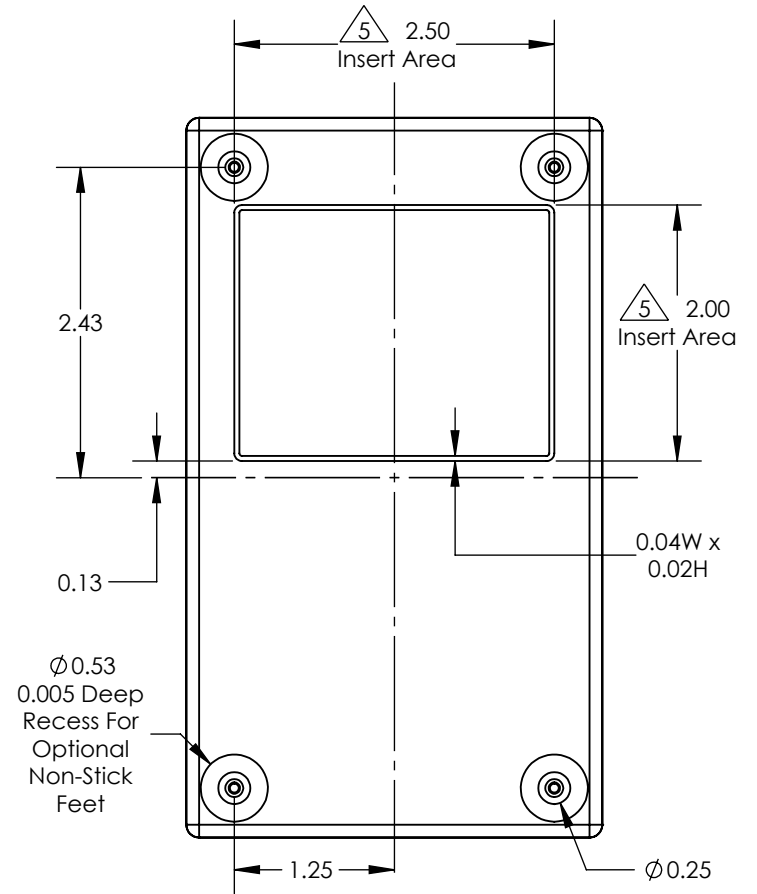
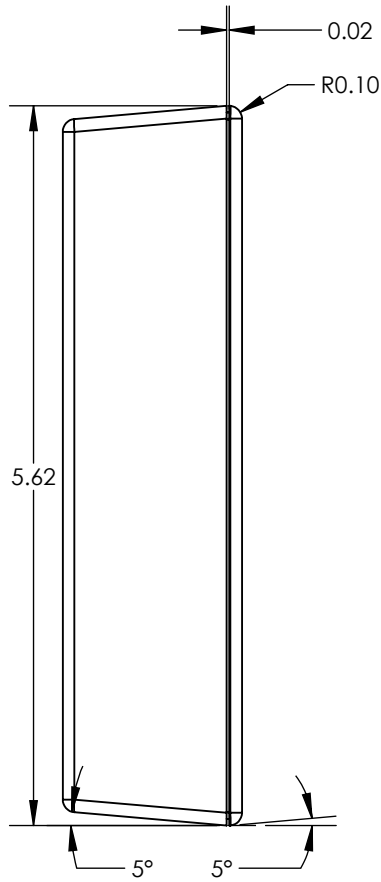
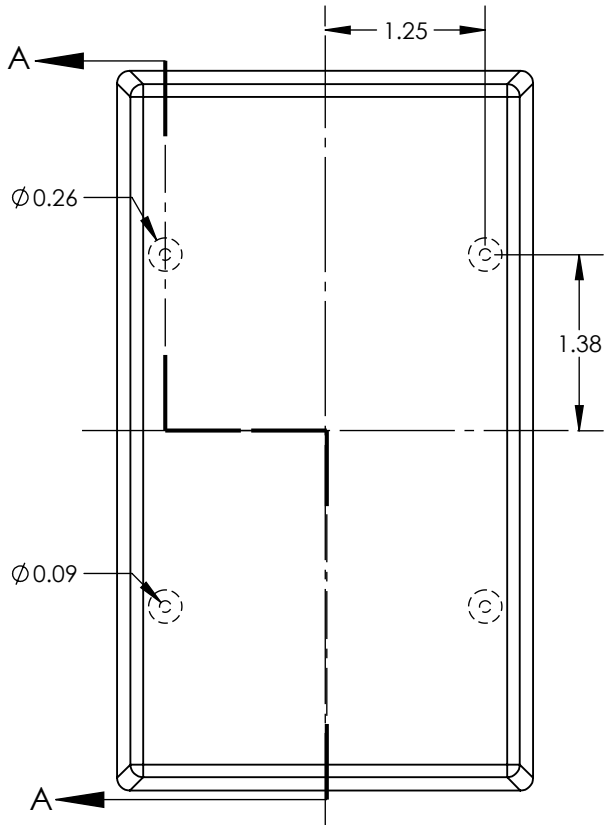

- Notes:
- Enclosure weight .22 lb / 101 g
 - 1) Enclosure meets or exceeds IP40 and NEMA 1
 - 2) Circuit Board drawings see sheet 3.
 - 3) All components are RoHS Compliant.
 - 4) Material: Top and Bottom ABS.
 - 5) Customizable molding areas. $\triangle 5$
 - 6) PCB Bosses accept #4 self tapping screw. $\triangle 6$

SERPAC 052 CIRCUIT BOARD

ELECTRONIC ENCLOSURES

Top & Bottom Option

